

HT400&DF3600,DF5050

LEAD FREE

DIGITAL INSTANT HOT WATER DISPENSER

HT400&DF3601,DF5051

LEAD FREE

DIGITAL INSTANT HOT AND COLD WATER DISPENSER

INSTALLATION MANUAL

Dawnway®

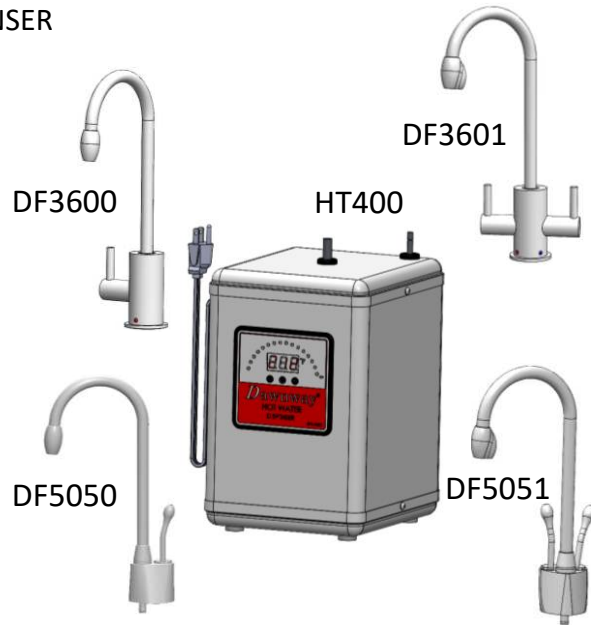

IMPORTANT INFORMATION

This digital hot water dispenser produces instant hot water of approximately 100° C (212° F, max.) as dispensed from the faucet.

This product is not intended to produce a continuous flow of hot water.

The standard model will produce up to 60 cups of water per hour at approximately 88° C (190° F). Due to high water temperature, for safety reasons, the tank is not under pressure. Consequently, there is a slight delay of water flow after the faucet has been activated.

This is normal and indicates that the expansion chamber is functioning properly.

This appliance is not intended for use by persons (including children) with reduced physical, sensory or mental capabilities, or lack of experience and knowledge, unless they have been given supervision or instruction concerning use of the appliance by a person responsible for their safety. Children should be supervised to ensure that they do not play with the appliance.

IMPORTANT SAFETY INSTRUCTIONS

PLEASE READ ALL INSTRUCTIONS VERY CAREFULLY

When using electrical appliances, basic safety precautions should always be followed including the following:

1. Read all instructions.
2. To protect against electrical shock, do not place cord, plugs, or appliance in water or other liquid.
3. Do not operate any appliance with a damaged cord or plug, or after the appliance malfunctions. Return appliance to the factory for examination, repair or adjustment. See Warranty insert.
4. Do not use outdoors or in damp area.
5. Do not let cord hang over edge of table or counter, or touch hot surfaces.
6. Do not use appliance for other than intended household use.
7. Do not attempt to service this product. Repairs should be done by authorized service personnel.
8. Do not let children operate. The water can cause severe burns.

SAVE THESE INSTRUCTIONS. THIS PRODUCT FOR HOUSEHOLD USE ONLY.

! WARNING

The alert symbols displayed above point to important safety information to make you aware of potential hazards that can cause serious injury or death. Please pay special attention to the information following these alerts and warnings. Failure to comply with these instructions can result in property damage, serious injury or death.

ELECTRICAL SUPPLY

! WARNING

THIS APPLIANCE MUST BE EARTHED, In the event of a malfunction, earthing provides a path of least resistance for the electrical current, thus reducing the risk of electrical shock.

This dispenser is rated 120VATTS , 50/60 Hz , maximum 10.9AMPS and should be connected to a main distribution board or consumer unit.

Before you begin connecting the electrical supply, you should be thoroughly familiar with electrical power and procedures. If you are not, consult an electrician.

IS THE DISPENSER EARTHED?

! WARNING

THIS APPLIANCE MUST BE EARTHED.

In the event of malfunction or breakdown, earthing reduces the risk of shock. This dispenser must be connected to an earthed, metal, permanent wiring conductor and connected to the equipment earthing terminal or lead on the dispenser.

HOT WATER CONCEPT

Unlike a household water heater, this dispenser tank is not pressurized for safety reasons. For a conventional household water heater, the faucet valve is placed after the heater tank resulting in a pressurized tank. For a hot water dispenser, the faucet valve is placed before the tank, creating an "open vent" style faucet and consequently no pressure is built up inside the tank.

**Operating inlet water pressure requirements :
172kPa (1.7bar, 25psi) Min and 861 kPa (8.6bar, 125psi) Max**

HT400

DIGITAL INSTANT HOT WATER DISPENSER

SPECIFICATION SHEET

- . 2.3 LITTER STAINLESS STEEL TANK
- . ALL STAINLESS STEEL TANK AND CASE
- . 1 YEAR WARRANTY TO ORIGINAL PURCHASER
- . MOUNTING BRACKET INCLUDED

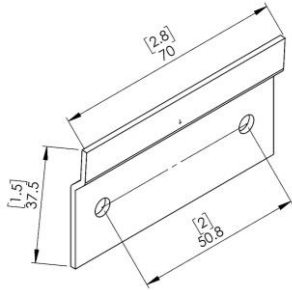

ELECTRICAL SPECIFICATION

- . 120 VAC, 50/60Hz
- . 750 WATTS, 6.3 AMPS
- . 1000 WATTS, 8.4 AMPS
- . 1300 WATTS, 10.9 AMPS
- . MAX TEMP 100 °C (212 °F)

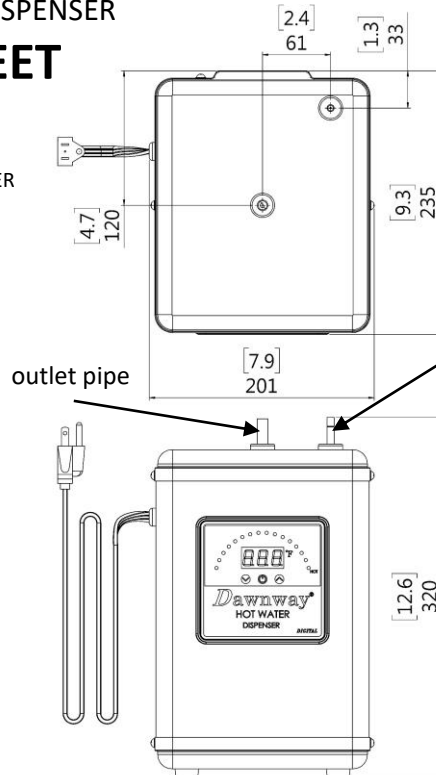

Dawnway



Inlet pipe

accessory :



quick-connect fitting
with filter and cap



quick-connect fitting

UNIT : $\frac{[INCH]}{mm}$

DF3600

LEAD FREE FAUCET

INSTANT HOT WATER DISPENSER

SPECIFICATION SHEET

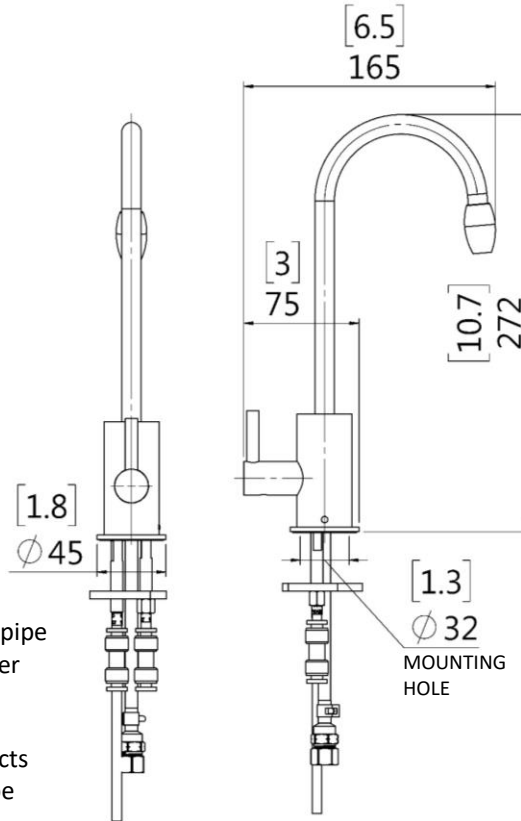
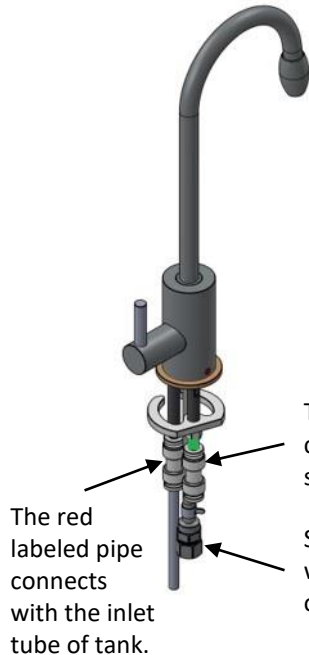

UNIT : $\frac{[\text{INCH}]}{\text{mm}}$

DF5050

LEAD FREE FAUCET
INSTANT HOT WATER DISPENSER

SPECIFICATION SHEET

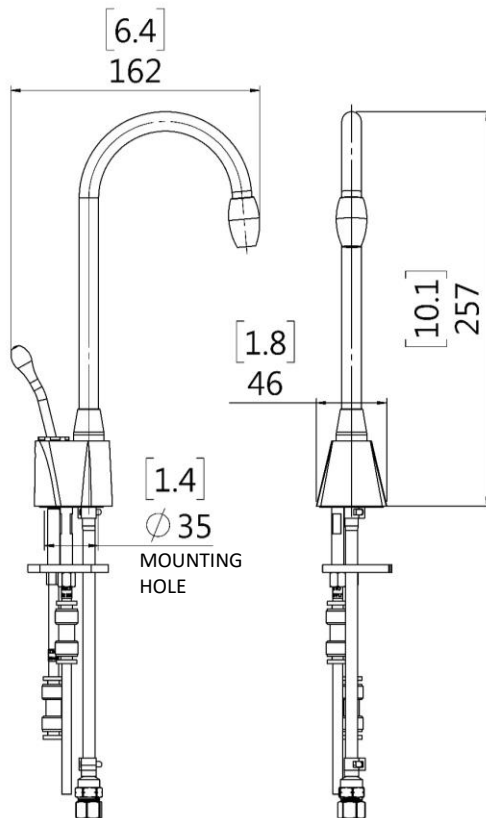
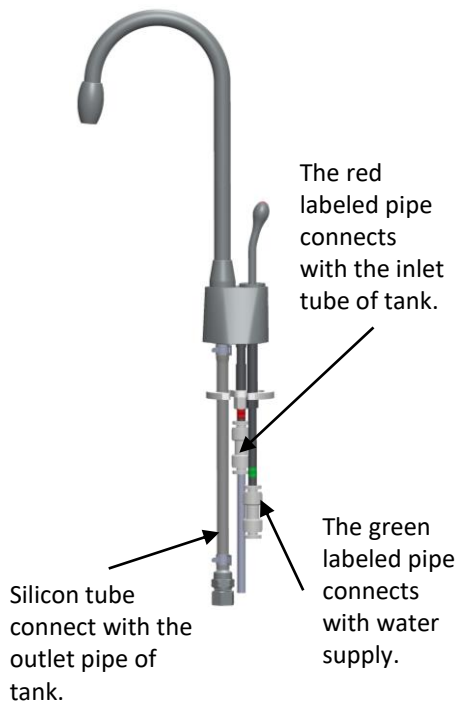

UNIT : $\frac{[INCH]}{mm}$

DF3601

LEAD FREE FAUCET
INSTANT HOT AND COLD WATER DISPENSER

SPECIFICATION SHEET

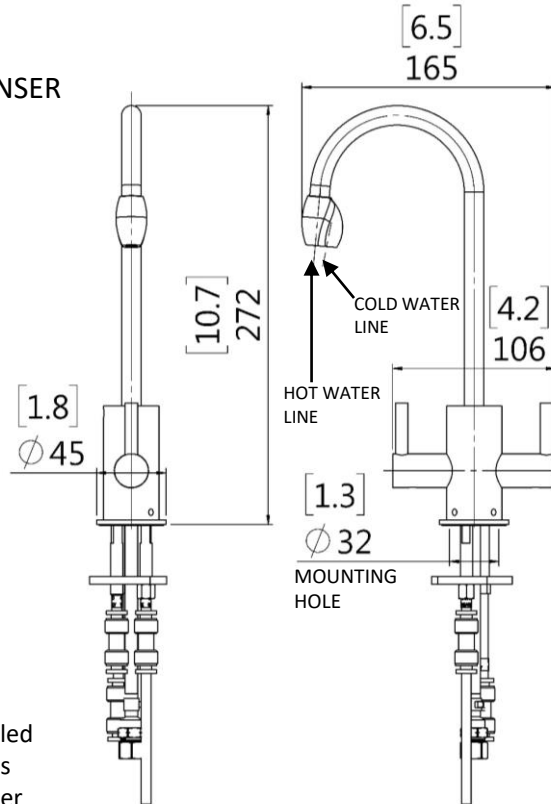
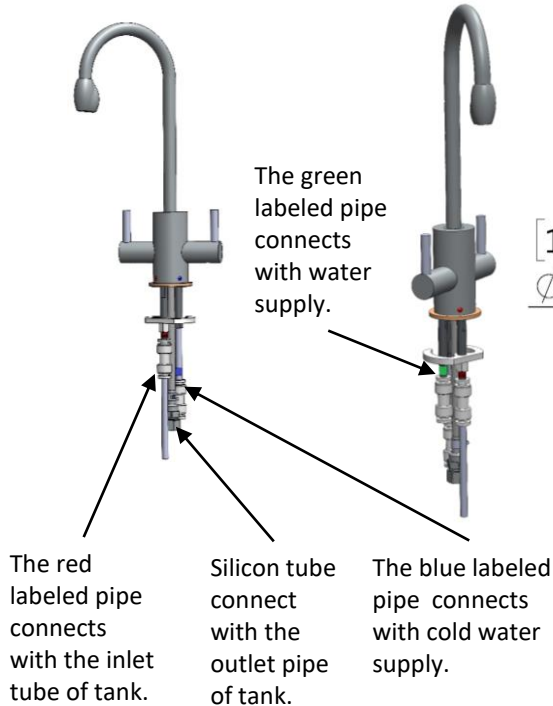

UNIT : $\frac{[INCH]}{mm}$

DF5051

LEAD FREE FAUCET
INSTANT HOT AND WATER DISPENSER

SPECIFICATION SHEET

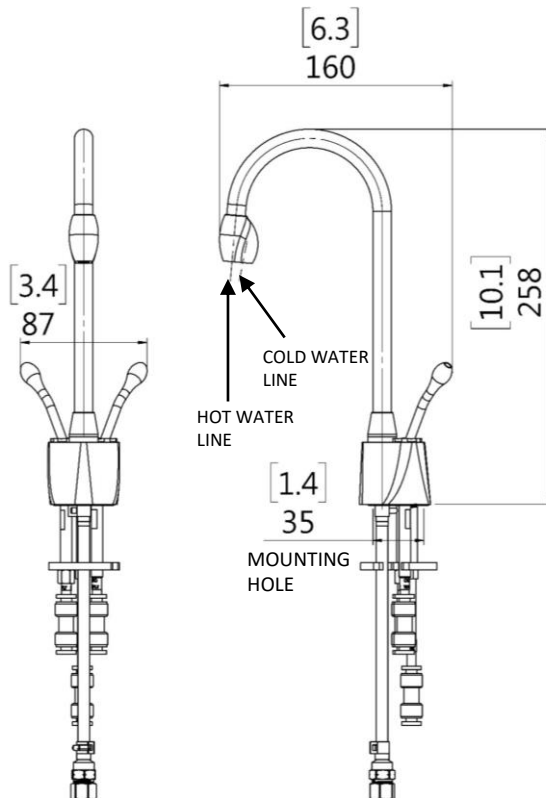
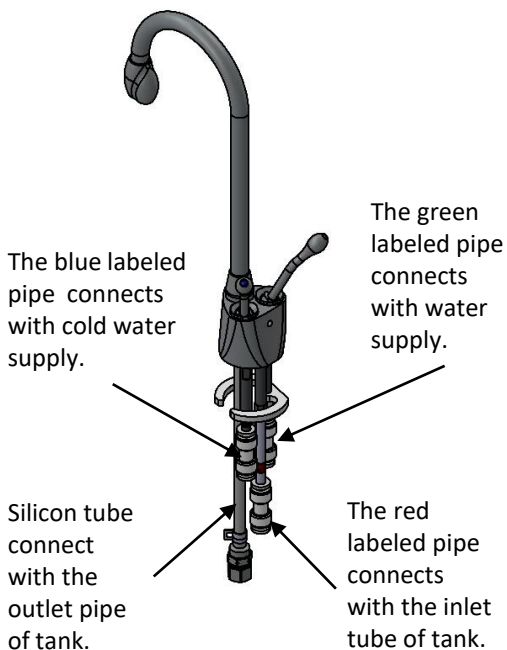

UNIT : $\frac{[INCH]}{mm}$

OVERVIEW OF A COMPLETED SET-UP

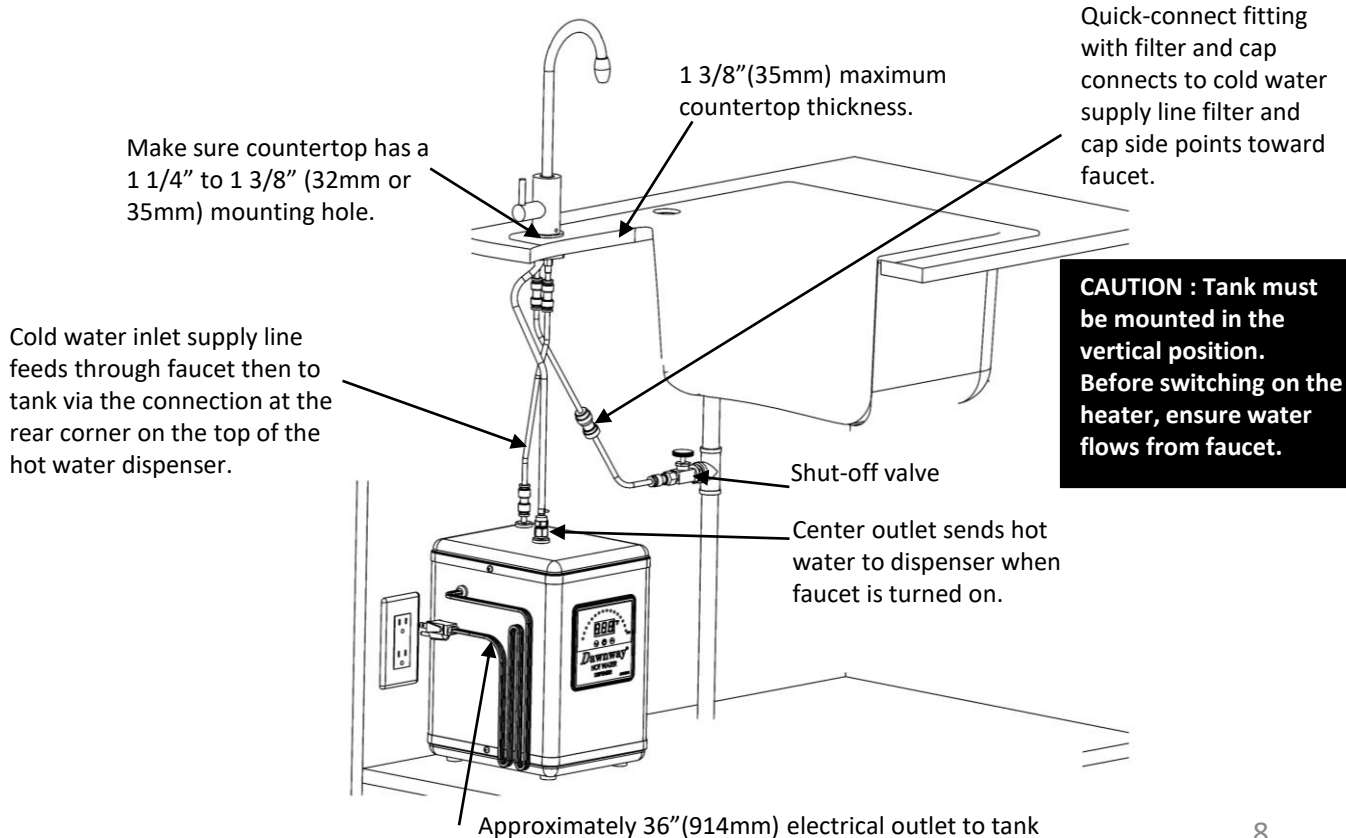

CONTROL PANEL

You will be instructed throughout this document to learn a method of operating digital water heater. Please refer to the diagram below to understand variety functions.

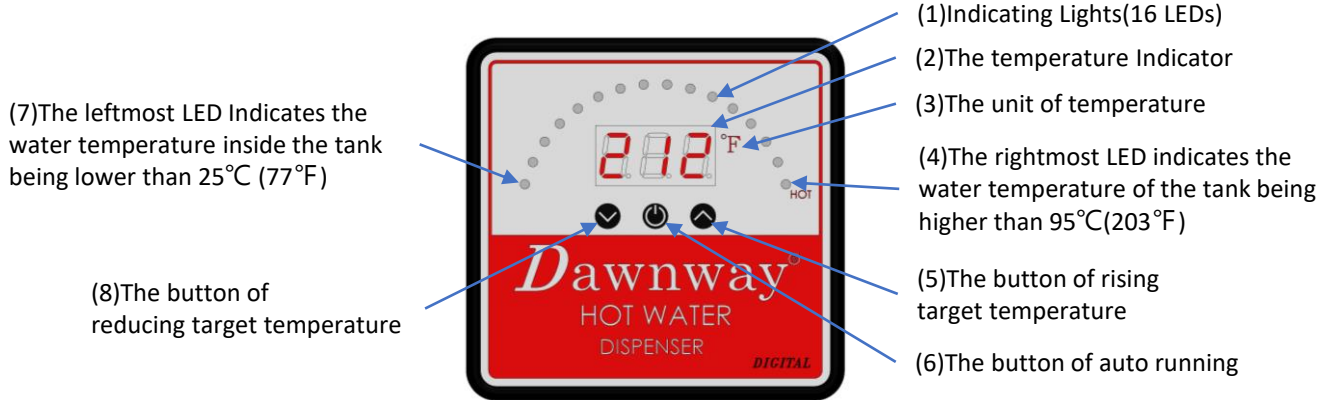

INSTRUCTIONS

1. The current temperature represents the current temperature of water inside the tank.
2. The target temperature represents that the water inside the tank will be heated up to this temperature.
3. The heating temperature represents that a temperature is 3 °C(5 °F) lower than the target temperature. The water heater will start working if the current temperature is lower.
4. After connecting to the power source, the indicating lights(1) will flash on from the leftmost LED(7) to the rightmost LED(4) sequentially and then light off all and repeat both three times. The temperature indicator(2) shows the current temperature. As the indicating lights(1) light off all, the water heater won't work.
5. Indicating lights(1) illustrate the current temperature or the water heater is working or not and auto running mode is on or off. Each LED represents 5 °C(9 °F).

OPERATING INSTRUCTION

1. Setting the target temperature

. Pressing and then releasing the button of rising target temperature(5), the temperature indicator(2) changes to show the target temperature and the target temperature rises up 1 °C(2~3°F) as it is higher than 90 °C(194°F); otherwise, it rises up 5 °C(9°F) each time. The highest target temperature is 100 °C(212°F).

. Pressing and holding on the button of rising target temperature(5), the target temperature will rise continually until releasing it, After releasing it and waiting for 3 secs, the temperature indicator(2) will return to show the current temperature.

. Pressing and then releasing the button of reducing target temperature(8), the temperature indicator(2) changes to show the target temperature and the target temperature reduces 1 °C(2~3°F) as it is higher than 90 °C(194°F); otherwise, it reduces 5 °C(9°F) each time. The lowest target temperature is 25°C(77°F).

. Pressing and holding on the button of reducing target temperature(8), the target temperature will reduce continually until releasing it, After releasing it and waiting for 3 secs, the temperature indicator(2) will return to show the current temperature.

2. Auto running mode

. Auto running mode means that if the current temperature is lower than the heating temperature, the water heater will start working and if the current temperature is equal to the target temperature, the water heater stops working.

. As the indicating lights(1) light off all, the water heater won't work. It is not on auto running mode.

. Pressing and then releasing the button of auto running(6), the water heater goes into the auto running mode. Repeating and releasing it, the water heater will turn off the auto running mode. Alternately pressing and releasing the button of auto running(6) could change the state of the water heater.

. When the water heater goes into the auto running mode, indicating lights(1) light on from the leftmost LED(7) to the LED of compared to the current temperature continuously.

. When the water heater is working, the indicating lights(1) light on from the leftmost LED(7) to the LED of compared to the current temperature sequentially and then light off all and will repeat until the water heater stops working.

3. Reheating function

. To Use this function, the water heater must be in the auto running mode.

. As the current temperature is between the target and heating temperature, the water heater won't work. If you want to get higher temperature soon. You can long press the button of auto running(6) for 3 secs, the water heater will start working immediately.

BEFORE YOU BEGIN INSTALLATION

WARNING

1. Before connecting to the power source, the tank must be filled with water.
2. Do not use an extension cord with this appliance. Appliance must be within approximately 36" (914 mm) of the power source.

3. Do not use any pipe sealing compounds as they may get inside the dispenser causing a discomforting taste and odor.
4. Determine a convenient location to mount faucet and tank. Important considerations when determining location include:
 - Installation must comply with local plumbing codes.
 - Read these instructions for the dispenser and heating tank before proceeding.
 - Dispenser will drip occasionally in use after water is drawn and tank is heating more water. This is normal.
 - Make sure the tank outlet supply tube has no loops or low areas.
 - Tighten fitting with an adjustable crescent or open wrench. Never use a pipe wrench.
 - Never dispense both hot and cold water at the same time.
 - Dispenser will occasional drip and spurt during water boiling. Lower target temperature to prevent spurting.
 - Be sure faucet is positioned where there will be no contact with the water flow when turning the faucet on and off to avoid burns.
 - Be sure to allow for 4" to 6" (102 mm to 154 mm) of space around the front and sides of the tank to allow for air circulation.
 - The container(s) you will use with the appliance such as a large cooking pan or carafe.

5. Mounting Hole Size Requirements :

- Existing hole in sink (the spray hose opening for example) or drilling another hole into the sink or countertop, You will need a 1 1/4" (32 mm) or 1 3/8" (35 mm) hole in your sink.
- Drilling into a stainless steel sink : You need a 1 1/4" (32 mm) or 1 3/8" (35 mm) knockout punch (available at most hardware stores) or drill a hole with an expandable drill.
- Drilling into a porcelain sink : Proper tools are required to drill through a porcelain or cast iron sink. If you are not familiar with this process you should consider having this done by a professional plumber.
- Do not attempt to drill sink holes without these special tools as you may severely damage your sink.
- Location of the hole should also provide easy access for tank connections.
- Tank must be mounted close to faucet to avoid kinking or pulling of lines. Lengthening of lines is not recommended as this may diminish performance of the appliance and void warranty.
- The thickness of the sink or counter must be less than 1 3/8" (35mm).

Materials required (not provided)



2 mounting bracket screws
(and 2 plastic anchors if
attaching to drywall)



1/4" (6.35 mm) O.D. PE
tube



shut-off valve
and "T" fitting"

Tools and Safety Equipment you may need (not provided)

- ruler or measuring tape
- pliers
- hand or electric drill
- small drill bit for starter holes
- 1 3/8" (35 mm) drill bit - if no sink hole exists
- safety glasses
- bucket or pan
- open-end wrench (es)
- gloves
- tubing cutter

Faucet Installation (stage 1)

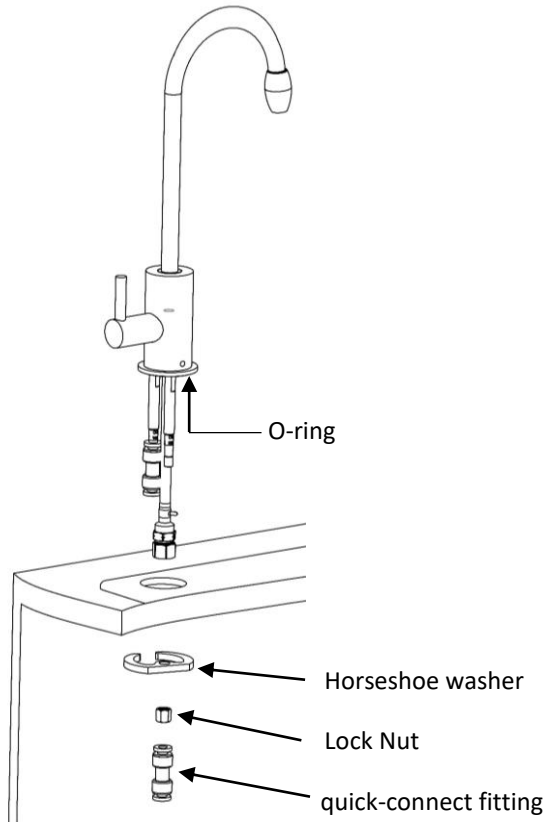

INSTALLING PROCEDURE :

1. Make sure countertop has a 1 1/4" or 1 3/8" (32mm or 35mm) mounting hole and countertop thickness is no more than 1-3/8"(35mm).
2. Make sure there is space for the handles to push back when opened.
3. Remove lock nut , horseshoe washer and quick-connect fitting from the mounting pipe .
4. Make sure O-ring is in the bottom of body . Slide the mounting hoses through the countertop.
5. Place the horseshoe washer on the mounting pipe and thread on lock nut. Make sure faucet is aligned properly and the hot handle is on the left. Tighten the lock nut.
6. Push back the quick-connect fitting on the mounting pipe.

Tank Installation (stage 2)

Position tank vertically beneath faucet so the flexible tube from the faucet reaches the center faucet supply tube on the tank and tank touches the wall. Mark the wall at the top of tank. Set tank aside.

Mark a second line 2 1/8" (54 mm) below the first line. Align bottom of bracket even with the second line and screw into place. If a stud is not available, drywall anchors may be used for additional support. Hang tank on bracket.

Be sure to allow for 4" to 6" (101.6 mm to 154.2 mm) air circulation around the front and sides of tank.

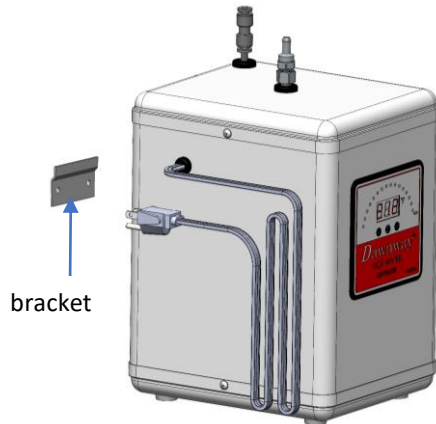

Mounting considerations to ensure back siphonage cannot occur:

This faucet must be mounted on a surface so that the faucet outlet is higher than the highest portion of the sink.

NOTE :

The tank must be positioned so the hose to the faucet does not twist or kink.

Connecting (stage 3)

Step 1 - Connect Faucet to Tank

- Connect the pipe of marked red label on the faucet by 1/4" (6.35 mm) PE tube to the rear pipe at the top corner of tank with the quick-connect fitting supplied with the appliance. (Do not use the quick-connect fitting with filter and cap.)
- Push line straight into quick-connect fitting as far as possible for both connections.
- Install the compression tube assy. on the outlet pipe of tank.
- Use pliers to open clamp and thread the silicon tube through clamp then push fully onto compression tube assy. Mounted on center outlet pipe on top of tank. The clamp should create a secure connection when properly installed.
- Be sure the silicon tube is not twisted or kinked. Hose may be shortened if necessary.

NOTE: DO NOT lengthen the silicon tube – dispenser performance will be impaired and warranty will be void.



Make sure the tank outlet silicon tube has no loops or low areas.

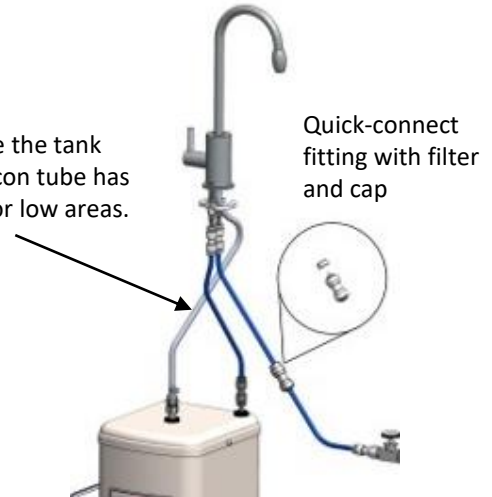

Step 2.0 Connect Cold Water Supply (for water supply without filter or chiller)

- Check filter in Quick-Connect Fitting with Filter and Cap .
- The cone-shaped screen filter comes seated inside the quick-connect fitting as shown in the illustration below, with the narrow end protruding through the cap which is also attached to the fitting. (The open or wide end of the screen is inserted into the fitting.) However, the filter may become dislodged in the shipping process.
- Check to see that it is seated correctly within the fitting. If the cap is still in place, pop cap off by slipping a screwdriver into the notch and lift off. Gently pull on the screen. If it comes loose, push in with a light jiggling or wiggling motion until it snaps into place. If installed property, a gentle pull should not dislodge it.
- Cold water is supplied to the tank through the faucet. Connect the cold water line to the faucet using the 1/4" (6.35 mm) supply line and the quick-connect fitting that contains a cone shaped screen filter (supplied with the tank.) The cap end of the fitting connects to the faucet line.
- It is suggested that a shut-off valve be installed between this connection and the cold water supply line.

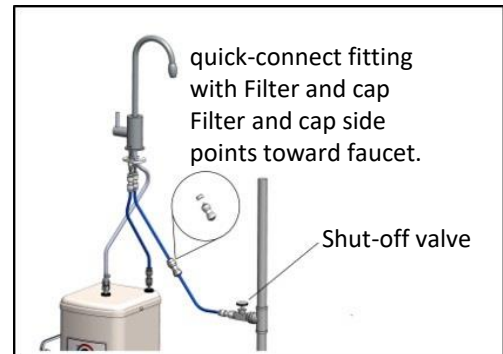

Step 2.1 - Connect Cold Water Supply For DF3600 & DF5050 Without Filter Or Chiller :

Connect a quick-connect fitting with filter and cap (attached with tank) between shut-off valve and faucet and cap side points toward faucet. See page 17.

Connect the pipe of marked green label on the faucet by $\frac{1}{4}$ "(6.35mm) PE tube to shut-off valve .
Do not connect directly to the water supply without shut-off valve.

Flush all lines before connecting.

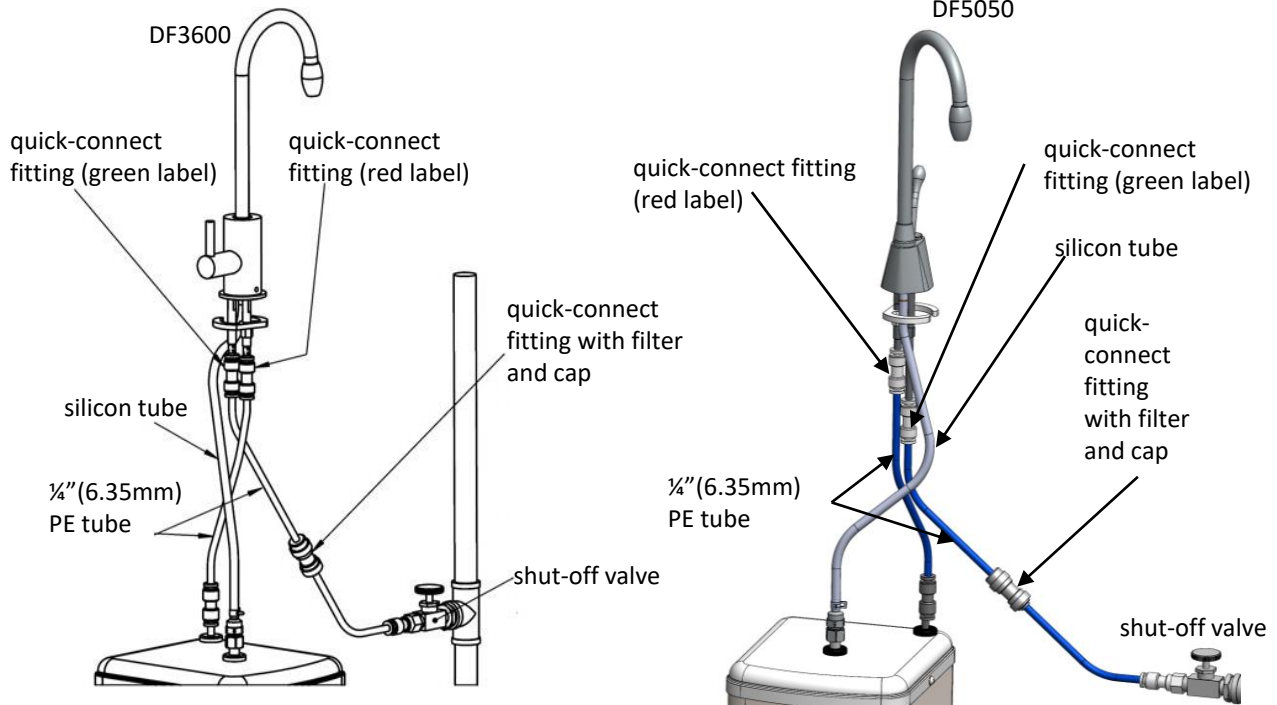

Step 2.2 - Connect Cold Water Supply For DF3601 & DF5051 Without Filter Or Chiller :

Install a shut-off valve with T quick-connect fitting in the main water supply line.

Connect ¼"(6.35mm) PE tube between faucet quick-connect fitting (blue label) and shut-off valve for cold water supply.

Connect ¼"(6.35mm) PE tube between faucet quick-connect fitting (green label) and quick-connect fitting with filter and cap and then connect to shut-off valve for hot side water supply.

Do not connect directly to the water supply without shut-off valve. **Flush** all lines before connecting.

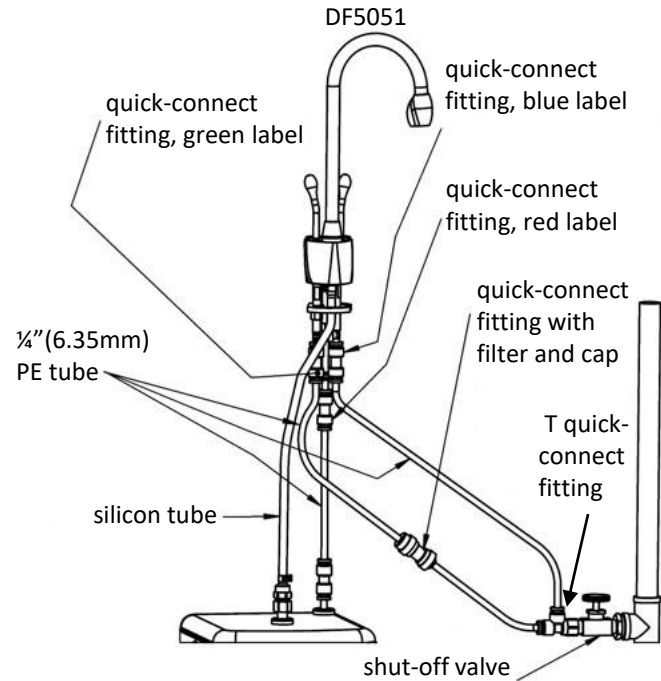
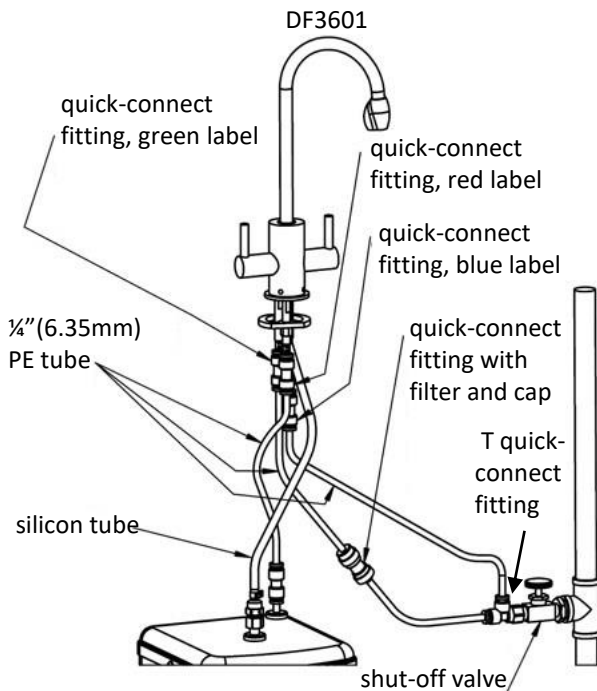

Step 2.3 - Connect Cold Water Supply For DF3600 & DF5050 With Filter :

Connect ¼" (6.35mm) PE tube between faucet quick-connect fitting (green label) and shut-off valve .

Do not connect directly to the water supply without shut-off valve.

Flush all lines before connecting.

If no water filter is used connect a quick-connect fitting with filter and cap (attached with tank) between shut-off valve and faucet.

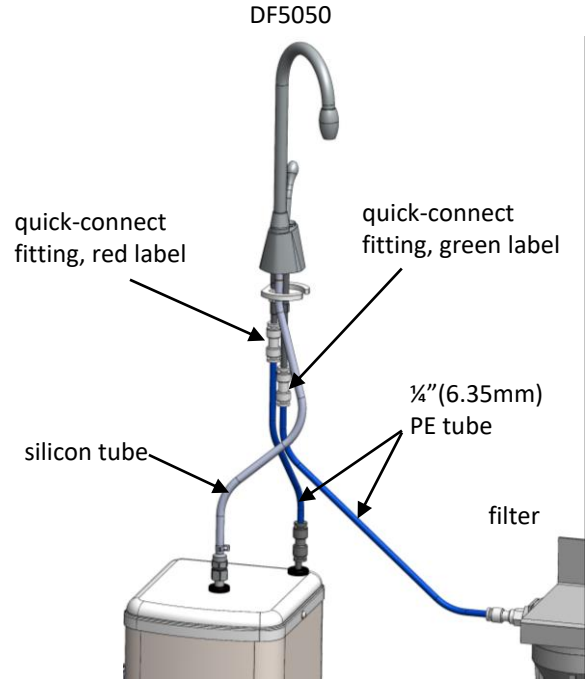
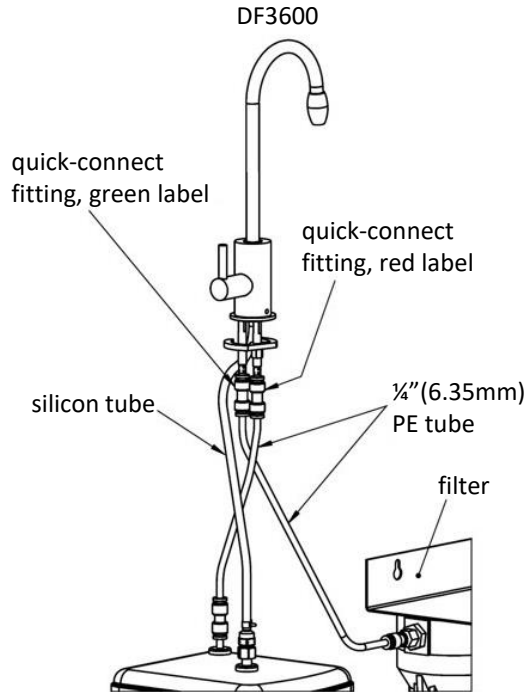

Step 2.4 - Connect Cold Water Supply For DF3601 & DF5051 With Filter :

Make sure there is a shut-off valve in the inlet of water filter and a T quick-connect fitting in the outlet of water filter. Connect $\frac{1}{4}$ "(6.35mm) PE tube between faucet quick-connect fitting (blue label) and outlet of water filter for cold water supply.

Connect $\frac{1}{4}$ "(6.35mm) PE tube between faucet quick-connect fitting (green label) and outlet of water filter for hot side water supply.

Do not connect directly to the water supply without shut-off valve. **Flush** all lines before connecting.

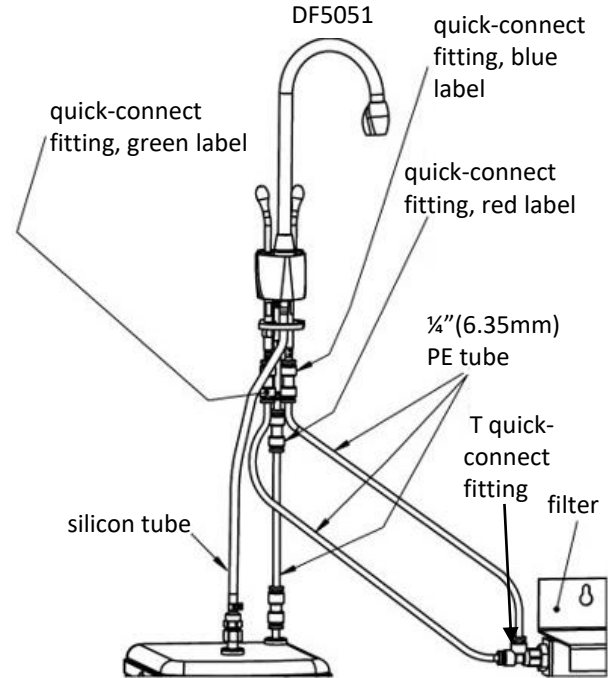
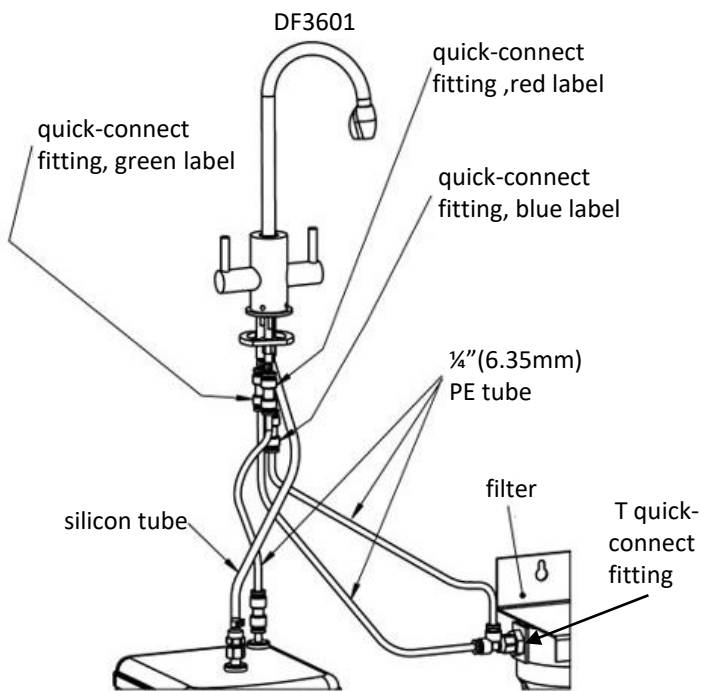

Step 2.5 - Connect Cold Water Supply For DF3601 & DF5051 With Water Chiller And Filter :

Make sure there is a shut-off valve in the inlet of water filter and a T quick-connect fitting in the outlet of water filter. Connect $\frac{1}{4}$ "(6.35mm) PE tube between outlet of water filter and inlet of water chiller for chiller water supply.

Connect $\frac{1}{4}$ "(6.35mm) PE tube between faucet quick-connect fitting (blue label) and outlet of water chiller for chilled water supply.

Connect $\frac{1}{4}$ "(6.35mm) PE tube between faucet quick-connect fitting (green label) and outlet of water filter for hot side water supply.

Do not connect directly to the water supply without shut-off valve. **Flush** all lines before connecting.

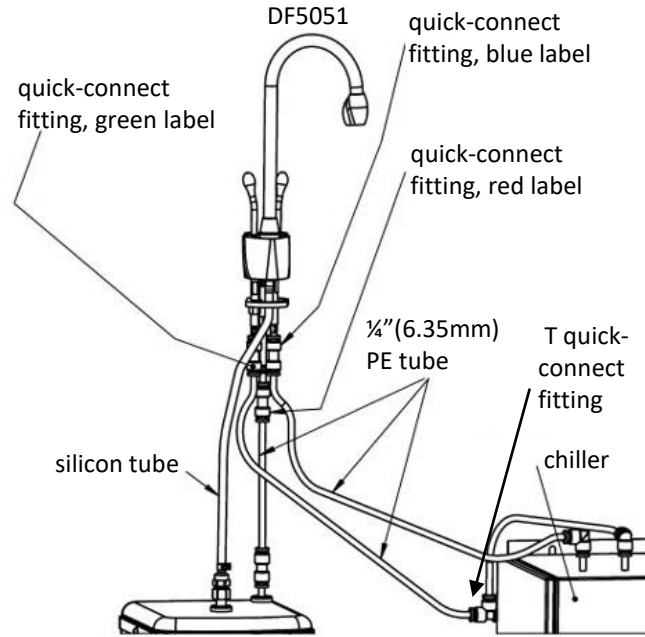
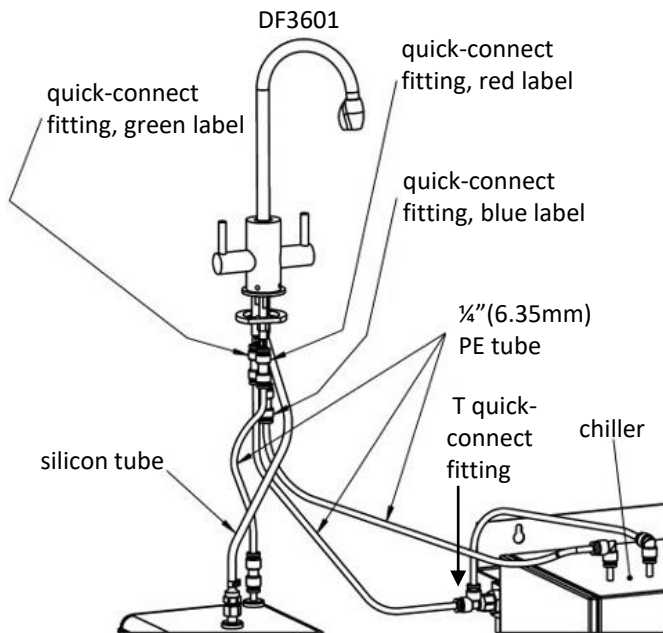

Step 3 - Check for Leaks

Make sure the inlet water supply pressure is 172kPa (25psi) Min and 861 kPa (125psi) Max.

Open valve in water line. Turn faucet on (hold if necessary) to fill tank (about 2 minute). When tank is full, water will flow from faucet. Allow water to flow from the faucet for approximately 10 seconds. Turn faucet off. Check for leaks.

Step 4 - Prepare for Power

Double check the tank is full water.

IMPORTANT INFORMATION - This dispenser is equipped with a Self Re-setting Thermal Fuse.

Fill tank with water before plugging the power cord from the tank into an electrical outlet.

If tank is empty and the water heater is serviced in the auto running mode when the power cord is connected, the self re-setting fuse in the heater control will disconnect the current to the heater after approximately one minute, thus protecting the heater from a "dry start" failure. The fuse in the heater control will self-reset after approximately 30 minutes.* Turn on the water supply to the tank and continue the installation.

Continued misuse will cause damage to the appliance and is detectable thus, voiding the warranty.

*(Re-setting of fuse can be accelerated by turning on the water supply and dispensing water until fuse re-sets in approximately 3 minutes.)

Step 5 - Test Installation

For electrical connection, please refer to Electrical Supply section on page 2.

Check the water heater to turn on the auto running mode (see page 10). Target temperature will be reached in about 15 minutes(as it is 100 °C(212°F)) and dispenser will be ready for use. Lower the temperature operating by setting lower target temperature (see page 10) if you notice vapor or a boiling noise.

To raise or lower the water temperature, you can re-set the target temperature. See page 10.

OPERATING INSTRUCTIONS

For Hot Water

DF3600

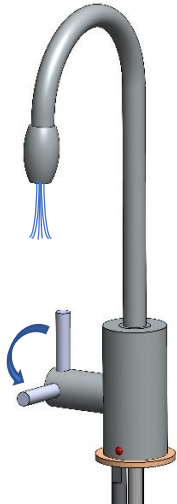

DF5050

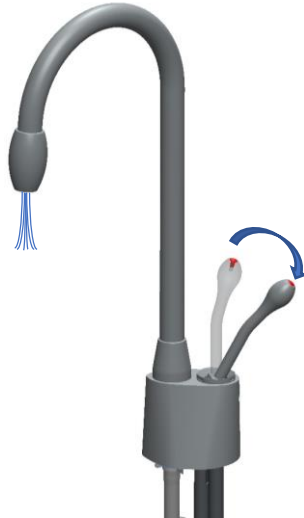

DF3601

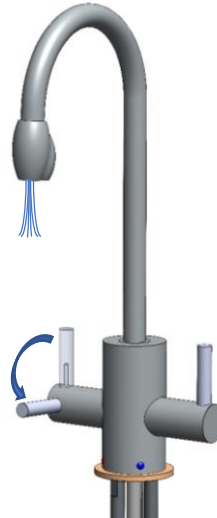

DF5051

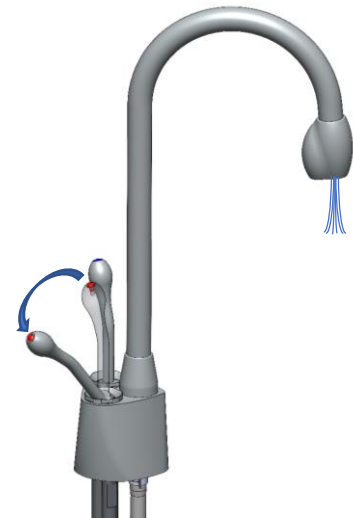

Depress the dispenser's **HOT** handle and hold it until **HOT** water flows from the spout. Release it, handle bar will automatically return to close position.

OPERATING INSTRUCTIONS

For Cold Water

DF3600



DF5050

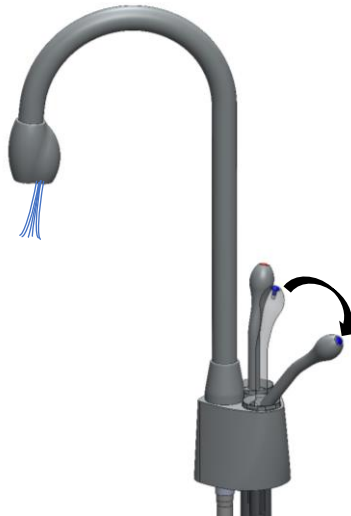

Turn the dispenser's cold handle forward until cold water flows from the spout. Turn it backward to close the water.

DF3601



DO NOT

DF5051



Never dispense both hot and cold water at the same time unless the water supply pressure is more than 30 psi.

CLEANING AND MAINTENANCE

Seasonal Shutdown

To prevent damage when dispenser is exposed to freezing temperatures, water must be drained.

1. Unplug dispenser tank from power supply.
2. Turn thermostat control dial to lowest position (fully counterclockwise).
3. Turn faucet on and run water until water is cold.
4. Place a 3-quart (2.8 L) container under drain plug at bottom of the tank. Use a screwdriver to remove the screw and O-ring in the drain tube opening. When tank is fully drained replace O-ring and screw. Tighten to reseal the drain.

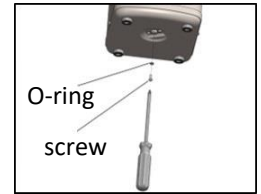

NOTE : Do not plug appliance into power supply if tank is empty.

Cleaning Quick-Connect Filter Screen at Cold Water Inlet

If you notice that the water flow is reduced, it may be necessary to clean the quick-connect screen. Refer to Installation Step 4.

1. Check heater is out of auto running mode. Turn on faucet and run water until it is cold to avoid possibility of burn.
2. Release cap with a screwdriver, pry it loose using the notch in the cap.
3. Also using the screwdriver push in on the smallest ring around copper line. This action releases tension, allowing disconnection of the copper line and quick-connect.
4. Pull cone shaped filter screen out (there will be slight tension) and clean with vinegar as necessary. Check cap and clean as necessary. If deposits have hardened, soak in vinegar for an hour or two. Then use a brush to clean.
5. Reassemble in reverse order of disassembly. Be aware, when inserting the screen back into place there is a slight resistance. Push until the screen "pops" into place. Check for leaks.
6. Check heater to go in the auto running mode. The dispenser will be ready in about 15 minutes.

QUICK-CONNECT FITTING WITH FILTER AND CAP

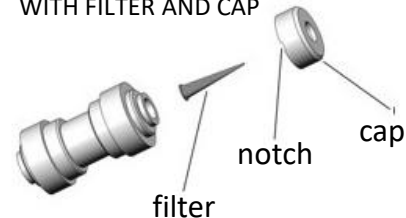

TROUBLESHOOTING

The following situations are not covered by the One Year Replacement Warranty.

1. Check that the water heater is going in the auto running mode. See page 10.
2. Water is not hot: (assuming cold water supply is connected properly and valve is open)
 - Check if dispenser is plugged in.
 - Raise the target temperature to 100 °C(212°F). This may produce boiling water in approximately 15 minutes and possibly be accompanied by a gurgling sound in the tank and/or water "sputtering" from the faucet. If the water boils, Lower the target temperature slightly until the gurgling and/ or "sputtering" stops. This should take place within 20 seconds. Wait 15 minutes and check the temperature of the water.

NOTE: The thermostat activates the heater after water temperature in the tank drops 3° C(5° F) from the target temperature. The dispenser does not produce a continuous flow of hot water.

3. Hot water drips or sputters from faucet:
 - Set the target temperature lower(see page 10).
 - Check that the hose connecting the faucet to the dispenser tank is not clogged, twisted or kinked.
 - Check if the filter screen of quick-connect with filter cap is clogged. (See CLEANING AND MAINTENANCE)
 - Rubber tubing from tank to faucet has been extended.
 - Water inlet pressure is lower. After raise water pressure, fully turn on faucet and run water for 1 minutes.
 - Do not slightly turn on faucet frequently. Fully turn on faucet and run water for 1 minutes.
3. Water does not flow right away or at all:
 - Due to high temperature and for safety reasons, the tank is not under pressure causing a slight delay in water flow.
 - Make sure all valves on water supply are open.
 - Check hose from faucet for twisting or tight bending.
 - Water inlet pressure is very low.
 - Check if the filter screen of quick-connect with filter cap is clogged. (See CLEANING AND MAINTENANCE)
4. Water boils or vapor appears:
 - Lower target temperature(see page 10).